

DIY Kit 130. Door Minder

This kit uses an infrared beam to monitor door & passage-ways or any other area. When the beam is broken a relay is tripped which can be used to sound a bell or alarm. Suitable for detecting customers entering a shop, cars coming up a driveway, etc. The IR beam is very strong. Distances over 25 feet can be monitored with this Kit. A 12VDC supply is required to power the kit. A 12V wall adaptor is fine. Provision has been made so that only one power supply needs to be used to power both units. The relays in this kit are rated to switch mains voltages.

The kit is constructed on single-sided printed circuit board. Protel Autotrax for DOS was used in the design.

CONSTRUCTION

The kit is built on two separate PCBs – a transmitter PCB (K130T) and a receiver PCB (K130R). Refer to the parts list to see which components belong to which board. Use the component overlay on each PCB to place the components.

Transmitter board

Insert the lowest height components first. Leave the infrared LED and power jack until last. Make sure that the electrolytic capacitor and 4 diodes are inserted correctly. IC sockets are supplied for the ICs. Note there are two links to add to the board. One is under an IC.

The IR LED can be mounted vertically or at right angles to the PCB. This will depend on how the transmitter will be mounted when in use. In either case the LED must be inserted the right way round. The flat edge on the LED should line up with the flat edge on the PCB overlay marked 'K'.

Lastly, if the distance to be monitored is less than about 10 yards then you will need to fit the 5mm shrink tubing over the IR LED. This narrows the radiating angle of the IR beam and makes it much more directional. The IR output is strong. It can easily bounce off walls etc to give false readings. Note that the red color shrink tubing is transparent to IR and will **not** act as IR shielding. The black tubing is the one to use.

Receiver board

As with the transmitter board, start with the lowest height components first - resistors, diodes, capacitors and transistors. Note the polarity of the electrolytic capacitors and diodes. Next insert the screw terminal block, power jacks and relay. Last of all is the infrared receiver module. The orientation is clearly shown on the PCB overlay: the detecting lens bump faces outwards. Power must be center positive. A protection diode D4 is there to protect the circuit if the wrong polarity is plugged in.

CIRCUIT DESCRIPTION - Transmitter Board

The transmitter board consists of two square-wave oscillators, one running at approx. 250Hz and the other running at 38kHz. The 38kHz frequency acts as a carrier wave and is required by the IR receiver module on the receiver board. This carrier wave is "ANDed" or modulated by the 250Hz frequency to produce an output signal that contains bursts of 38kHz at a rate of 250Hz. This signal is used to drive an infrared LED. The oscillators are made by

using two 555 timer ICs set up as "astable" (free running) multivibrators. IC1 is used for the 250Hz oscillator. Resistor R1 and R2 and capacitor C1 set the frequency. Another 555 chip, IC2, is used for the 38kHz oscillator. Resistors R4 and R5 and capacitor C3 set the frequency.

Notice the diodes D1 and D3. These are provided to create a "symmetrical" output. Normally the external capacitor C1 (C3) charges through resistors R1 and R2 (R4 and R5) and discharges through R2 (R5). Without the diodes this output waveform would have a longer "high" time than the "low" time. The diode bypasses resistor R2 (and R5) when the capacitor is charging, so that it is only charged via R1 (or R5). This gives the same charging and discharging time and so the output waveform has equal high and low times.

The charge time (output high) is given by:

$$T_{HIGH} = 0.693 \times R1 \times C1 \text{ (or } 0.693 \times R4 \times C3)$$

The discharge time (output low) is given by:

$$T_{LOW} = 0.693 \times R2 \times C1 \text{ (or } 0.693 \times R5 \times C3)$$

The output frequency = $1 / (T_{HIGH} + T_{LOW})$

For an excellent website describing all this and more go to

<http://www.uoguelph.ca/~antoon/gadgets/555/555.html>

For an animation of the 555 as an astable multivibrator see

http://www.williamson-labs.com/480_555.htm

The output from the IC1 is coupled via diode D2 and resistor R3 to the 'trigger' input of IC2. When the IC1 output is low it stops IC2 from running and IC2's output is forced high (no IR LED current). When IC1 output is high, IC2 runs and the IR LED is pulsed at 38kHz.

The Waitrony IR LED is driven directly from the output of IC2. Resistor R6 sets the maximum LED current. With a 12VDC supply the current is about 45mA (the LED drops 2V across it when conducting). Lowering the value of R6 will increase the current through the LED thus boosting the signal strength. This may be necessary if the kit is used outside in direct sunlight or if you need "very long range". Keep in mind that the maximum current that the 555 can handle is 200mA. See the IR LED data sheet at

<http://kitsrus.com/pdf/ie-0530hp.pdf>

Receiver Board

The receiver consists of an IR receiver module that detects the incoming IR beam from the transmitter. The IR signal is used to keep a capacitor charged which in turn holds a relay operated. When the beam is broken the capacitor discharges and the relay releases.

An IR receiver/detector module, RX1, is made up of an amplifier/filter circuit tuned to detect a 38kHz frequency. The output pin is low whenever a 38kHz signal is detected. See the IR receiver module data sheet at

<http://kitsrus.com/pdf/pic12043.pdf>

DIY Kit 130. Door Minder

When the IR beam is present the relay is operated.

Not all Receiver Modules are the same. IR decoder module looks for a manufacturer-specific leader code before it decodes the modulated signal. Our kit produces an NEC compatible Leader code. The Kodenshi PIC37043LM and PIC12043LO decoder modules are the ones we use in this Kit. If you use the incorrect IR decoder module the relay will not be operated continuously but will drop out after less than a second after power is applied.

The output of RX1 is the 250Hz signal from the transmitter. This signal is passed via transistor Q1, capacitor C1 and diode D2 to capacitor C2. C2 is fully charged during the high portion of the signal. It starts to discharge during the low portion of the signal via LED L1, resistor R4 and transistor Q2. However the discharge time is much longer than the off time of the signal so the voltage across C2 is always enough to keep transistor Q2 on and therefore the relay operated.

When the beam is broken the output of RX1 is high. Transistor Q1 is off and capacitor C2 is no longer being recharged. It will eventually discharge to the point where transistor Q2 will turn off and the relay will release. The “turn off” delay is determined by the time constant of resistor R5 and capacitor C3. With the values used it is approx. half a second.

Capacitor C1 prevents a steady DC voltage on the collector of Q1 from charging C2. This would occur if the beam was not present or the beam was a **continuous** 38kHz signal. In other words, the receiver module will only respond to a **pulsed** 38kHz signal.

LED L1 gives a visual indication when the IR beam is present and is used to help with installation and setup. Zener diode Z1, resistor R6 and capacitor C4 provides a stable 5.6V supply for the IR module. The Goodsky RWH relays are mains rated: 250V/12A; 120VAC/15A.

INSTALLATION

For ease of operation, the transmitter board can be powered from the receiver board when they are relatively close together. Two extra DC plugs have been supplied for this. Connecting wire for the length required must be supplied by you. Otherwise two separate power supplies are required. The receiver board contains two DC jacks connected in parallel. Power from a 12VDC source is connected to one jack. A lead can then be connected to the other jack and run to the transmitter board.

Aligning the transmitter and receiver is a matter of pointing the transmitter IR LED at the receiver board and moving it around until the red LED on the receiver board lights and the relay clicks on. This indicates that the beam is being received.

Note: With power applied the relay is normally operated and only releases when the beam is broken. The relay contacts

labelled “NO” (Normally Open) and “NC” (Normally Closed) refer to when the relay is released. With the relay operated, the “NO” contact will be connected to the “C” contact and the “NC” contact will be unconnected.

IF IT DOES NOT WORK

Poor soldering (“dry joints”) is the most common reason that the circuit does not work. Maybe change R4 & R5 on the Tx board to 1K8. Are the electrolytic capacitors & diodes around the right way round? Have you fitted the 5mm tubing to the IR LED on the transmitter board? A new version of this kit was released December, 2001. The transmitter board has been completely revised.

Web Address & Email

Website: kitsrus.com email: peterhk@kitsrus.com

PARTS LIST – K130

Transmitter board

Resistors (0.25W 5%, carbon)

| | | |
|-----------|-----------|---|
| 220R..... | R6..... | 1 |
| 1K..... | R3..... | 1 |
| 2K2..... | R4,5..... | 2 |
| 2K7..... | R1,2..... | 2 |

Capacitors

| | | |
|-------------------------------------|------------------|---|
| 10nF ceramic..... | C2,3,4..... | 3 |
| 1uF electrolytic mini..... | C1..... | 1 |
| 1N4148 signal diode..... | D1,2,3..... | 3 |
| 1N4004 power diode..... | D4..... | 1 |
| LM/NE555 Timer IC..... | IC1,2..... | 2 |
| IR LED..... | L1..... | 1 |
| 2.5mm DC jack..... | X1..... | 1 |
| IC sockets, 8 pin..... | for IC1,2..... | 2 |
| Tubing, BLACK, 5mm x 25mm long..... | (fitted over L1) | 1 |
| PCB, K130TV2..... | | 1 |

Receiver Board

Resistors (0.25W 5%, carbon)

| | | |
|-----------------------------|---|---|
| 470R..... | R3,6..... | 2 |
| 6K8..... | R1,2,4..... | 3 |
| 47K..... | R5..... | 1 |
| 10uF 25V electrolytic..... | C1,2,3..... | 3 |
| 100uF 16V electrolytic..... | C4,5..... | 2 |
| 1N4148 signal diode..... | D1,2..... | 2 |
| 1N4004 power diode..... | D3, 4..... | 2 |
| 5.6V 400mW zener diode .. | Z1..... | 1 |
| BC547 transistor, NPN..... | Q2..... | 1 |
| BC557 transistor, PNP..... | Q1 (might be marked Q3 on the PCB)..... | 1 |
| LED, 5mm red..... | L1..... | 1 |
| IR receiver module..... | RX1..... | 1 |
| 2.5mm DC jack..... | X1,2..... | 2 |
| Terminal block, 3-way..... | X3..... | 1 |
| Relay, 12V SPDT..... | RL1..... | 1 |
| “Goodsky” RWH-SH-112D | | |
| PCB, K130R..... | | 1 |

DIY Kit 130. Door Minder

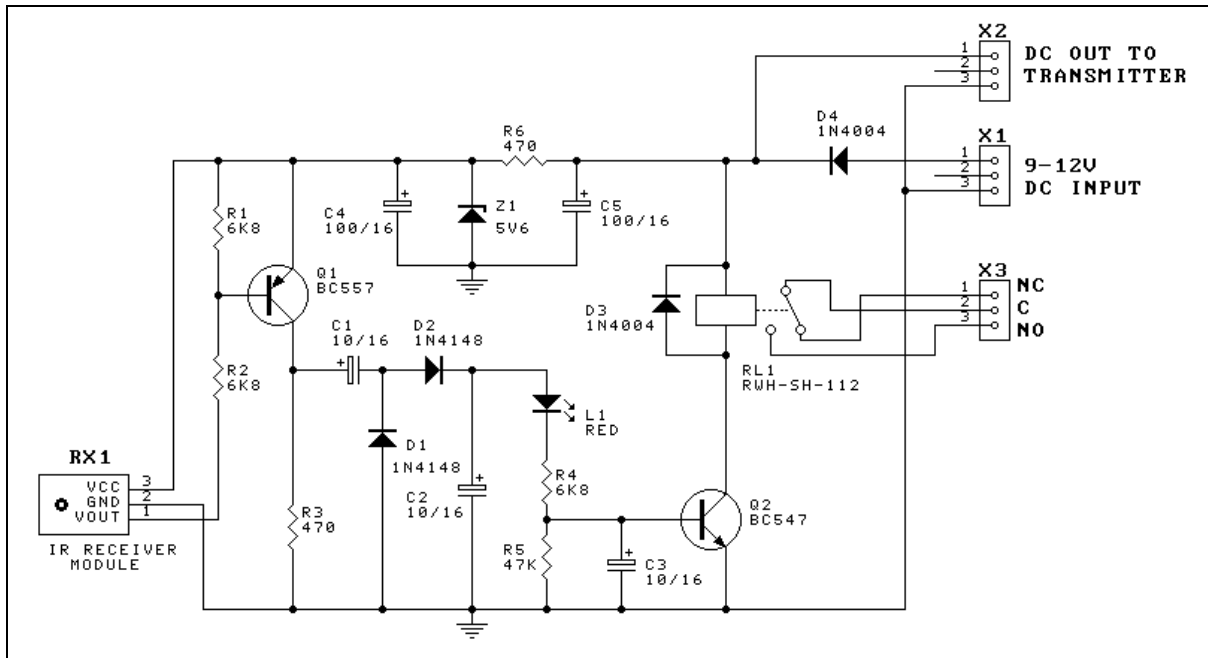

Door Minder - Receiver Module

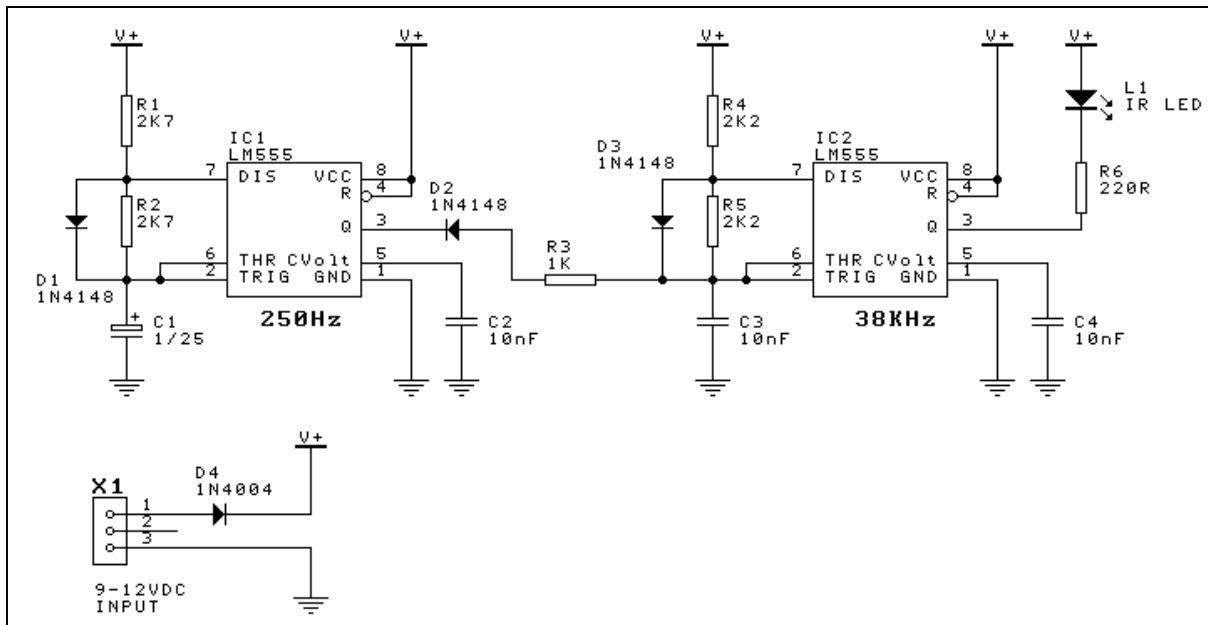

Door Minder - Transmitter Module