

Kit 107. 1W Stereo Amplifier



This is a 1 watt stereo amplifier module Kit using the TDA 7053 from Philips. It is particularly suited to battery operation, providing 1 watt per channel from only a 6V DC supply. It will operate best from 6 – 12 V DC and requires no heat-sink for normal use.

TDA 7053 Features :

- Short circuit protected
- Thermal protection
- Low power consumption
- Good stability
- Gain is internally set to 39 dB

Specifications :

D.C. input :	3 – 18 V max. at > 0.5 – 1A.
Idle current	< 16 mA, 9 mA typical.
Power output	> 2.5 W/ch. @ 8 - 16 ohm, 12V. > 1 Watt/ch. @ 4 - 16 ohms, 9V > 1 Watt/ch. @ 4 - 8 ohm, 6V. > 0.25 Watt RMS continuous.
Freq. Resp.	< 10 Hz to > 100 kHz, – 3dB
THD	< 1 % @ 0.25W/channel, 8 ohm
S/N ratio	> 65 dB (> 70 dBA)
Gain	~ 40 dB.
Max. Input	~ 50 mV RMS, 12 V DC supply.
Input Z	~ 4.7 k ohm.
Size	33 mm * 36 mm

Assembly Instructions :

Assembly is very straight forward. Start with the two resistors, saving one of the cut off wire leads. A wire link is required on the board, and you can use the resistor lead to add that next. Make sure you get the integrated circuit and the electrolytic capacitor the correct way around. The electrolytic capacitor is polarized, it has a + or - marked on it and must be inserted correctly into the PCB. The IC and socket have a notch at one end, which is marked on the PC board overlay. Solder the socket in place first before installing the IC itself.

Check the supply voltage and polarity before connecting the battery or power supply. If it does not work, re-check all component positions and polarity. Check all solder joints, and all external wiring. The IC itself is quite robust, and there is very little else to go wrong.

Remember when testing, it will not produce full output for more than a short duration because of limited heat dissipation, or with DC input less than 6V. For normal music applications you should have no problems as long as the output is kept from severe clipping. This will result in audible distortion and should be avoided.

Circuit Description :

The TDA7053 Integrated Circuit does nearly all the work, so there are only a few external components. C1 and C2 provide power supply decoupling or filtering. R1 and R2 provide a DC ground reference for the input signals, and may be increased if your source requires a higher load impedance. Do not use more than 100k ohms.

Since the I.C. operates in BTL (bridge tied load) configuration, the outputs are floating with respect to ground. Therefore **NO output leads should be connected to ground.**

The Philips data sheet contains all the necessary information about the TDA7053. You may download it from the software download page on our website at :

<http://www.kitsrus.com>

Kit 107. 1W Stereo Amplifier

Circuit Diagram

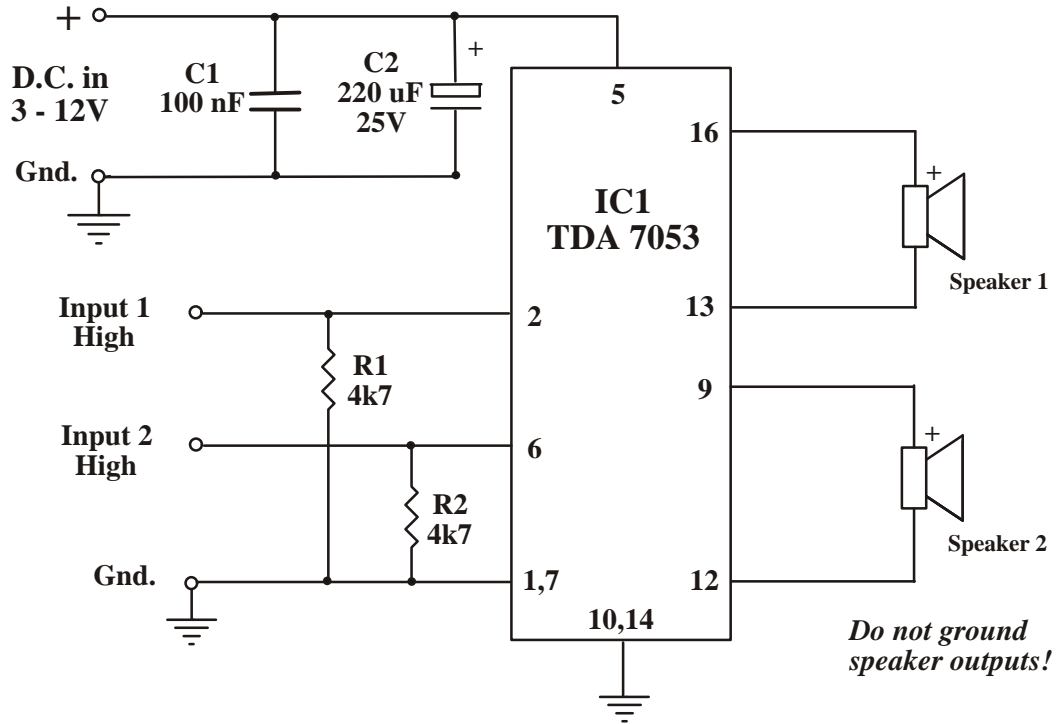

Components :

Resistors

4K7 (yellow, violet, red) ..R1, R2.... 2

Capacitors

100nF (104) monoblock... C1..... 1

220uF 25V ecap C2..... 1

Misc.

TDA7053.....IC1 1

Kit 107 Printed Circuit Board 1

16 pin IC socket 1

9V Battery snap..... 1

Kit 107. 1W Stereo Amplifier

Harmonic Distortion at 1 kHz.
0.25 W output, 8 ohm load,
12V DC supply.

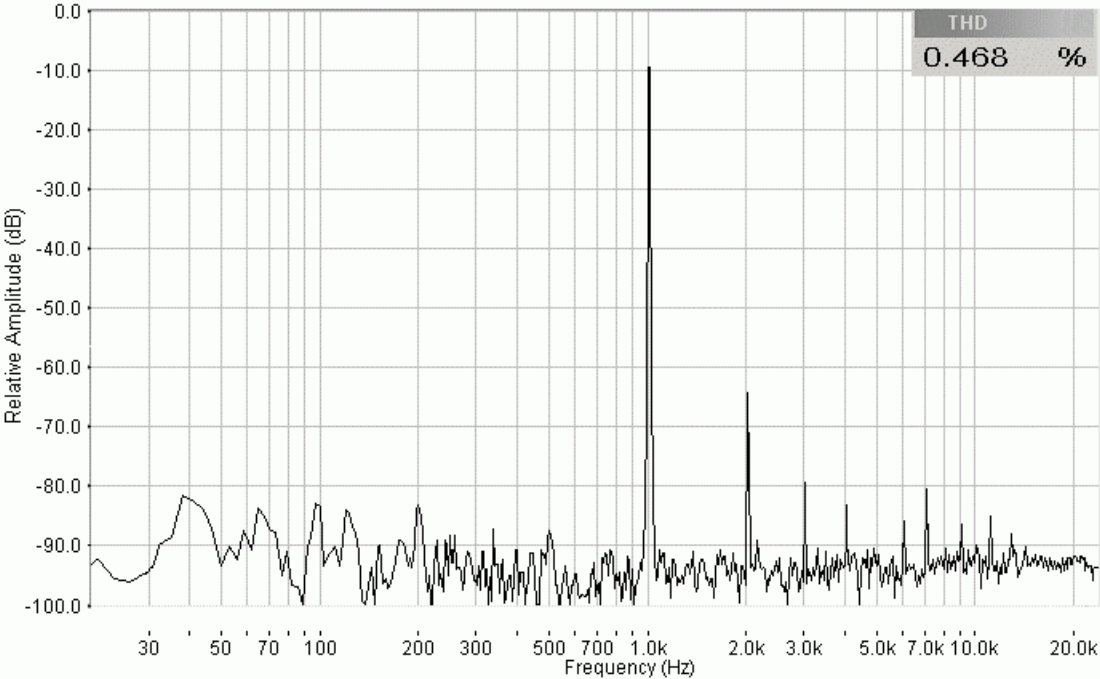

Photo of completed circuit.

