

Kit 106. 50 Watt Audio Amplifier



This kit is based on an amazing IC amplifier module from ST Electronics, the TDA7294. It is intended for use as a high quality audio class AB amplifier in hi-fi applications. It has very low noise and distortion, wide bandwidth and good output current capability, enabling it to supply high power into both 4Ω and 8Ω loads. It has both short circuit and thermal protection, so is quite robust.

With the addition of a handful of parts and a suitable power supply, this module will deliver over 50W RMS into 4 or 8 ohms with < 0.1% Total Harmonic Distortion (THD) and < 0.1% Intermodulation Distortion (IMD). A similar circuit was published in *Elektor* magazine, 11/96.

It is also suitable as a replacement power amp stage, or upgrade for many existing amplifiers of between 30W-50W, provided they have a suitable dual supply, and most do.

Specifications (± 35V D.C. power supply)

Output power :	> 50W RMS, 4-8 Ω load ~ 80W into 4Ω max. ~ 60W into 8Ω max.
Gain	24 dB (30dB modification)
Input sensitivity :	1.3V for 50W, 8 ohm 0.9V for 50W, 4 ohm (0.6V, 50W, 8Ω, G=30dB)
Input impedance :	10kΩ
Signal-to-Noise ratio :	> 95 dB, (>105 dBA)
Frequency response :	~ 20Hz - 200kHz, -3 dB
Slew rate :	> 10V/uS
THD :	< 0.01%, 1W-40W, 1kHz < 0.1%, at 50W, 20-20kHz
IMD :	< 0.01%, 1W

Construction :

** Please note C6 on the PCB overlay is shown the wrong way around. The positive should go to pin 6 of the IC, as shown on the circuit diagram.*

Start with the lowest height components first, resistors and capacitors. Keep one of the longer lead off cuts to use as the link. Be careful to get the electrolytic capacitors in the correct way around. The positive lead is marked on the overlay. The negative lead is marked on the body of each capacitor. Leave the IC and the big electrolytic capacitors to last. Make sure that the IC is at right-angles to the PCB and the heatsink chosen will fit, before soldering.

Important : You must supply a heavy duty heatsink rated at least 1.4 °C/W or better. This is not supplied

with the kit, it must be obtained separately then drilled to suit. If building two kits for a stereo amp, you may prefer to use one larger heatsink, and mount a board at either end. This is often cheaper than two smaller ones. A silicon impregnated insulating washer and insulation bush are provided in the kit.

How it Works :

Most of the circuitry is contained within the IC module. The input signal is applied to pin 3 via capacitor C1 and low-pass filter R1/C2. The filter improves the pulse response and helps stop RF signals. The lower -3dB point is determined by R2/C1 and R4/C3. This is approximately 20Hz for the values used. The upper -3dB point is over 200kHz. C7/C8 and C9/C10 provide extra power supply filtering or decoupling.

R3/R4 are the feedback resistors. The gain is $1+R3/R4$ which is approx 16 times, or 24dB. If you wish to increase the input sensitivity you may change the resistors to suit. Changing R3 to 22k would increase the gain to 30dB and lower the input required for 50W into 8Ω, to 0.6V, without affecting performance too much. If you reduce the value of R4 you will also need to increase C3 to maintain bass response, as this sets the feedback low frequency roll off.

Pin 10 is a mute input and pin 9 provides a standby mode. Muting should always take place before standby mode is selected. Connecting these pins permanently to the supply rail (insert links provided) ensures that the amplifier comes on immediately on power up. Any switch-on clicks may be eliminated by increasing the time constants of R5/C4 and R6/C5 if necessary. See the ST data sheet for more details.

Power Supply :

The maximum supply voltage of the IC is ± 40V. However the maximum dissipation of the IC can be exceeded even at a lower voltage. Therefore the supply voltage used need not be more than ± 35V. This can be constructed using a 50V center tapped transformer, a diode bridge rated at 5A (min.) and a pair of electrolytic capacitors, as shown below.

A lower secondary voltage transformer could also be used but the reduced DC voltage will result in less power output into 8 ohms. You can still obtain 50W into 4 ohms with only 24V supply rails. A 36V C.T. transformer will give you approx ± 25V rails. The mains transformer used should be rated at a minimum of 80VA. If you want to run two modules in a stereo amplifier you can use a common power supply. In this case the transformer should be rated at 150VA or greater.

Kit 106. 50 Watt Audio Amplifier

Testing :

Before applying power, check that all parts are inserted in the correct locations. Make sure that the electrolytic capacitors are the right way round. Check the power supply voltages before connecting the power supply to the amplifier. Then connect the power supply leads with a current meter (or multimeter set to read amps) in series with the positive rail. Connect a load resistor to the speaker output, and short out the input terminals. Make sure there are links inserted for *Mute* and *Standby*. Switch on the power and check that the current settles down to between 20 and 60mA. There will be a brief surge as the filter capacitors charge. Also check the DC voltage at the output is not more than 200mV before connecting a speaker.

Note : *Do not operate the module without a heatsink.* You must have the heatsink fitted, otherwise the thermal overload protection circuit will cut in and switch the device off. The heatsink tab on the TDA7294 IC is internally connected to the negative supply rail. *Therefore If the heatsink is connected to an earthed metal enclosure, the IC must be insulated from the heatsink.* If not, the negative supply rail will be shorted to ground. A silicon impregnated rubber washer and a plastic insulating bush are provided for this purpose.

To minimize noise and distortion, keep the input signal leads away from the power supply and output leads. Use screened cable for input leads, and suitably large cables for all DC power wires and speaker connections. Remember the current may be a few amps in each case. Make sure all earths connect at a single point to eliminate hum caused by ground loops.

Operation :

No input attenuation is provided, so if you are not using a separate pre-amp then you may require a volume control. This can be a 10k ohm logarithmic potentiometer connected as shown. If you are using two modules for stereo, then a dual gang pot will be required. A CD player can be connected like this and will drive the module to full power without a pre-amp. Alternatively you might like to use one of our stereo pre-amp or tone control kits.

The maximum continuous power you can obtain will depend largely on the size of the power supply and the size of the heatsink used. make sure both are sufficiently large for the intended application. The IC has internal thermal protection that causes the mute to cut in at 145°C and switches the amplifier into standby at 150°C. You should however avoid operating at such high temperatures by using a suitably large heatsink for the average power you

need. A heatsink fan is an alternative to a larger heatsink, if fan noise is not a problem.

If it does not work :

Dry joints caused by poor soldering are the most common reason that the circuit does not work. Check all soldered joints carefully under a good light. Resolder any that look suspicious. Check that all components are in their correct position on the PCB, and the electrolytic capacitors in the right way round. Make sure you have inserted the links for *Mute* and *Standby*. Remember that the metal tab on the IC is internally connected to the negative supply rail, so check that the negative supply rail is not shorted to ground.

The data sheet on the TDA7294 IC is available from the ST Electronics web site at :

<http://www.st.com>

or our web site at :

<http://www.kitsrus.com>

Parts List :

Resistors (1/4 W carbon)

150R (brown green brown)	R1	1
10K (brown black orange)	R2, R3, R5	3
680R (blue grey brown)	R4	1
22K (red red orange)	R6	1

Capacitors

1u5F or 1u MKT polyester	C1	1
2n7F MKT polyester	C2	1
22uF 63V electrolytic	C3, C6	2
10uF 63V electrolytic	C4, C5	2
2200uF 50V electrolytic	C7, C9	2
100nF MKT polyester	C8, C10	2

Semiconductors

TDA 7294	IC1	1
----------	-----	---

Miscellaneous

K106 PCB		1
Header, 2 pin		2
Jumper		2
Silicon impregnated insulating washer		1
Insulating bush		1
Screw, 3 x 12mm		1
Nut, 3mm		1
Washer, 3mm		1

Kit 106. 50 Watt Audio Amplifier

Circuit Diagram

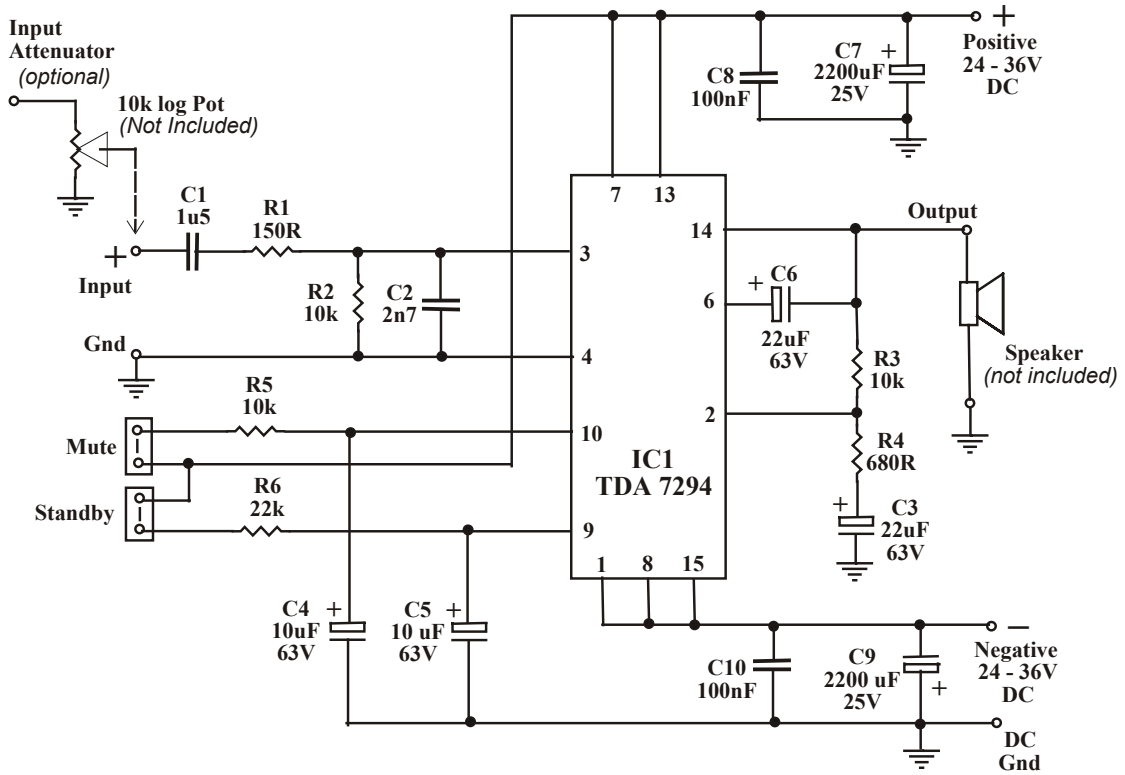

** Please note C6 is shown incorrectly on the PCB overlay. The circuit diagram is correct.*

Suggested Power supply circuit

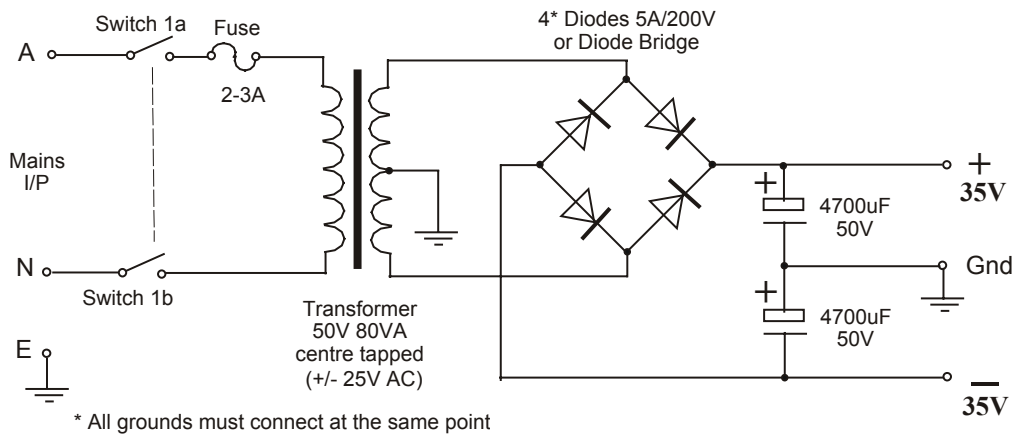

For a stereo pair you may double the VA of the transformer, diode bridge current, increase capacitance and fuse rating. Alternatively use two complete supplies.

Kit 106. 50 Watt Audio Amplifier

**Harmonic Distortion at 50W RMS
4ohms, 1 kHz input**

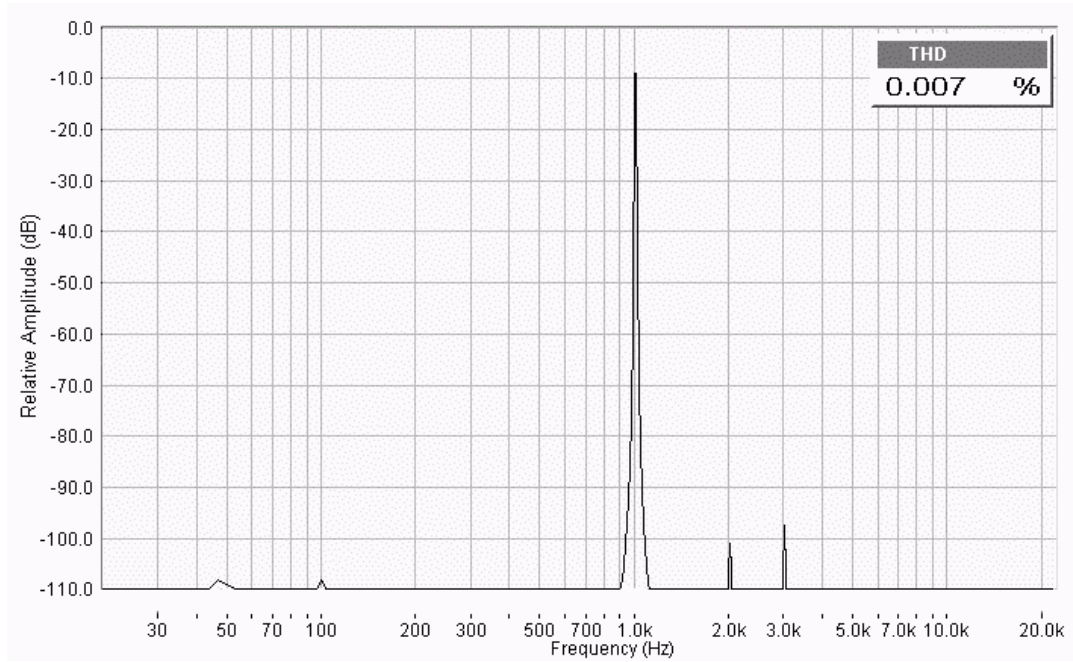
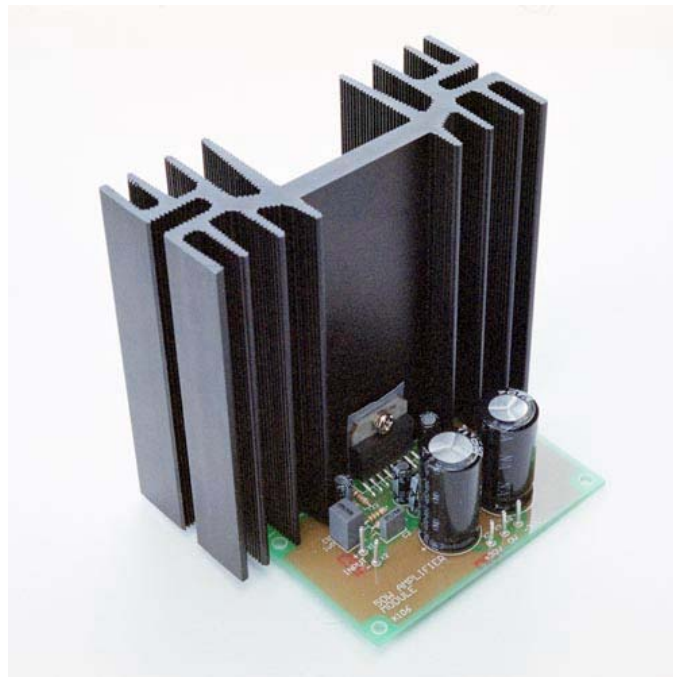
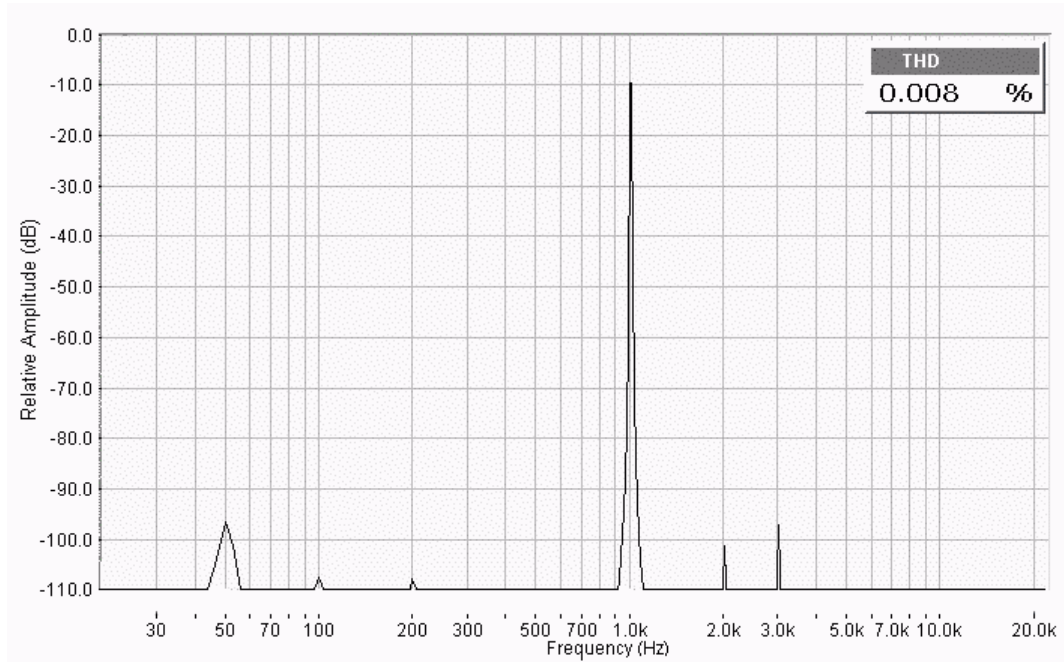

Photo of completed Kit (heatsink must be purchased separately.)



Kit 106. 50 Watt Audio Amplifier

Harmonic Distortion at 1W, 1 kHz



Intermodulation Distortion at 1W 250 Hz, 8020 Hz, 4:1

