



# GB-333HR3D

## DATA SHEET

**GLOBE**  
受管制文件  
Controlled Document  
Issued by Spec. Center

QC: 

ENG: 陳錦興

Prepared By: 呂滙芳



### Features

- ◆ High intensity
- ◆ Popular T-1 3/4 diameter package
- ◆ Selected minimum intensities
- ◆ Wide viewing angle
- ◆ General purpose leads
- ◆ Reliable and rugged

### Package Dimension:

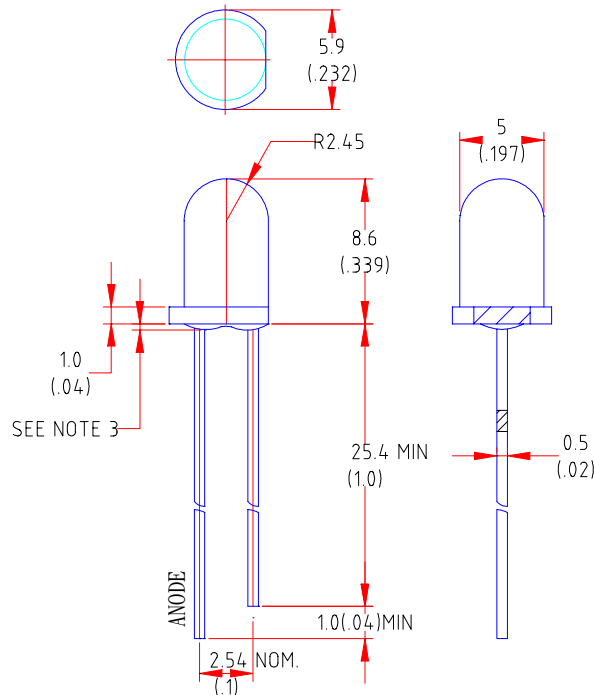

Part NO. GB-	Lens Color	Source Color
333HR3D	Red Diffused	Super Red

### Notes:

1. All dimensions are in millimeters (inches).
2. Tolerance is  $\pm 0.25(.010)$ mm unless otherwise noted.
3. Protruded resin under flange is 1.0mm(.04”) max
4. Lead spacing is measured where the leads emerge from the package.
5. Specifications are subject to change without notice



**Absolute Maximum Ratings at Ta=25°C**

Parameter	GB-333HRD-3	Unit
Power Dissipation	100	mW
Peak Forward Current (1/10 Duty Cycle, 0.1ms Pulse Width)	100	mA
Continuous Forward Current	20	mA
Derating Linear From 50°C	0.4	mA/°C
Reverse Voltage	5	V
Operating Temperature Range	-40°C to +80°C	
Storage Temperature Range	-40°C to +80°C	
Lead Soldering Temperature [4mm(.157") From Body]	260°C for 5 Seconds	



**Electrical Optical Characteristics at Ta=25°C**

Parameter	Symbol	Min.	Typ.	Max.	Unit	Test Condition
Luminous Intensity	$I_v$		80		mcd	$I_f=20\text{mA}$ Note 1
Viewing Angle	$2\theta_{1/2}$		35		Deg	Note 2 (Fig.1)
Peak Emission Wavelength	$\lambda_p$		657		nm	Measurement @Peak (Fig.1)
Dominant Wavelength	$\lambda_d$		641		nm	Note 3
Spectral Line Half-Width	$\Delta\lambda$		24		nm	
Forward Voltage	$V_f$		1.9	2.6	V	$I_f=20\text{mA}$
Reverse Current	$I_r$			100	$\mu\text{A}$	$V_r=5\text{V}$

Note:

1. Luminous intensity is measured with a light sensor and filter combination that approximates the CIE eye-response curve.
2.  $\theta_{1/2}$  is the off-axis angle at which the luminous intensity is half the axial luminous intensity.
3. The dominant wavelength,  $\lambda_d$  is derived from the CIE chromaticity diagram and represents the single wavelength which defines the color of the device.



Typical Electrical / Optical Characteristics Curves  
(25°C Ambient Temperature Unless Otherwise Noted)

