

LM340 Series Three Terminal Positive Regulators

National Semiconductor
Application Note 103
George Cleveland
August 1980



INTRODUCTION

The LM340-XX are three terminal 1.0A positive voltage regulators, with preset output voltages of 5.0V or 15V. The LM340 regulators are complete 3-terminal regulators requiring no external components for normal operation. However, by adding a few parts, one may improve the transient response, provide for a variable output voltage, or increase the output current. Included on the chip are all of the functional blocks required of a high stability voltage regulator; these appear in *Figure 1*.

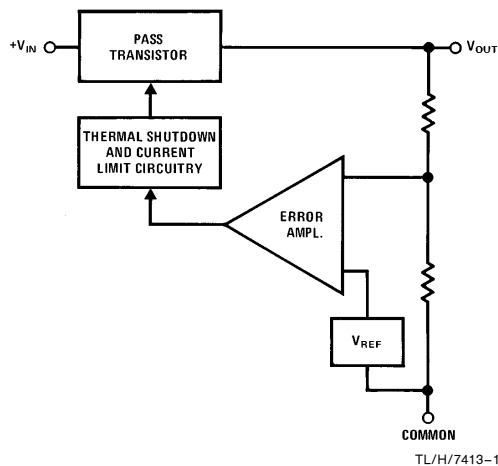

FIGURE 1. Functional Block of the LM340

The error amplifier is internally compensated; the voltage reference is especially designed for low noise and high predictability; and, as the pass element is included, the regulator contains fixed current limiting and thermal protection. The LM340 is available in either metal can TO-3 or plastic TO-220 package.

1. CIRCUIT DESIGN

Voltage Reference

Usually IC voltage regulators use temperature-compensated zeners as references. Such zeners exhibit $BV > 6.0V$ which sets the minimum supply voltage somewhat above 6.0V. Additionally they tend to be noisy, thus a large bypass capacitor is required.

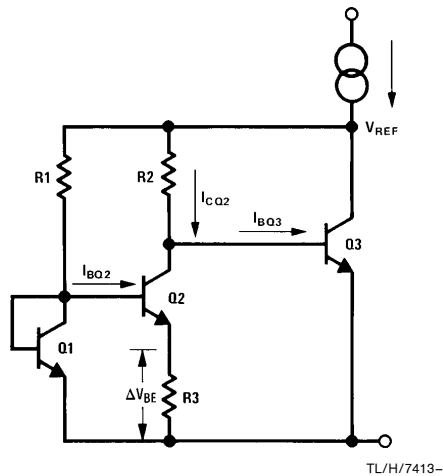

FIGURE 2. Simplified Volt Reference

Figure 2 illustrates a simplified reference using the predictable temperature, voltage, and current relationship of emitter-base junctions.

Assuming $J_{Q1} > J_{Q2}$, $I_{CQ2} \gg I_{BQ2} = I_{BQ3}$,
Area (emitter Q1) = Area (emitter Q2), and

$$V_{BEQ1} = V_{BEQ3}, \quad (1-1)$$

then

$$V_{REF} \approx \left(\frac{kT}{q} \ln \frac{R2}{R1} \right) \frac{R2}{R3} + V_{BEQ3} \quad (1-2)$$

Simplified LM340

In *Figure 3* the voltage reference includes R1–R3 and Q1–Q5. Q3 also acts as an error amplifier and Q6 as a buffer between Q3 and the current source. If the output drops, this drop is fed back, through R4, R5, Q4, Q5, to the base of Q3. Q7 then conducts more current re-establishing the output given by:

$$V_{OUT} = V_{REF} \frac{R4 + R5}{R4}$$

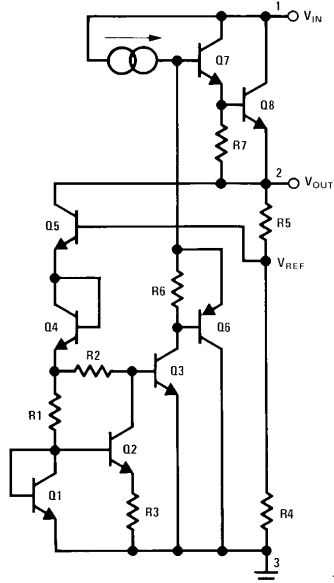

FIGURE 3. LM340 Simplified

TL/H/7413-3

Complete Circuit of the LM340 (Figure 4)

Here $(J_{Q2}, J_{Q3}) > (J_{Q4}, J_{Q5})$ and a positive TC ΔV_{BE} appears across R6. This is amplified by 17, $(R6/R6 = 17)$ and is temperature compensated by the V_{BE} of Q6, Q7, Q8 to develop the reference voltage. R17 is changed to get the various fixed output voltages.

Short Circuit Protection

A) $V_{IN} - V_{OUT} < 6.0V$: There is no current through D2 and the maximum output current will be given by:

$$I_{OUT MAX} = \frac{V_{BEQ14}}{R16} \approx 2.2A \quad (T_j = 25^\circ C) \quad (1-4)$$

B) $V_{IN} - V_{OUT} > 6.0V$: To keep Q16 operating within its maximum power rating the output current limit must decrease as $V_{IN} - V_{OUT}$ increases. Here D2 conducts and the drop across R16 is less than V_{BE} to turn on Q14. In this case I_{OUT} maximum is:

$$I_{OUT MAX} = \int \frac{1}{R16} \left(V_{BEQ14} - \frac{[(V_{IN} - V_{OUT}) - V_{ZD2} - V_{BEQ14}]}{R13} R14 \right) \quad (1-5)$$

$$= 0.077 [37.2 - (V_{IN} - V_{OUT})] \quad (A) \quad \text{at } T_j = 25^\circ C$$

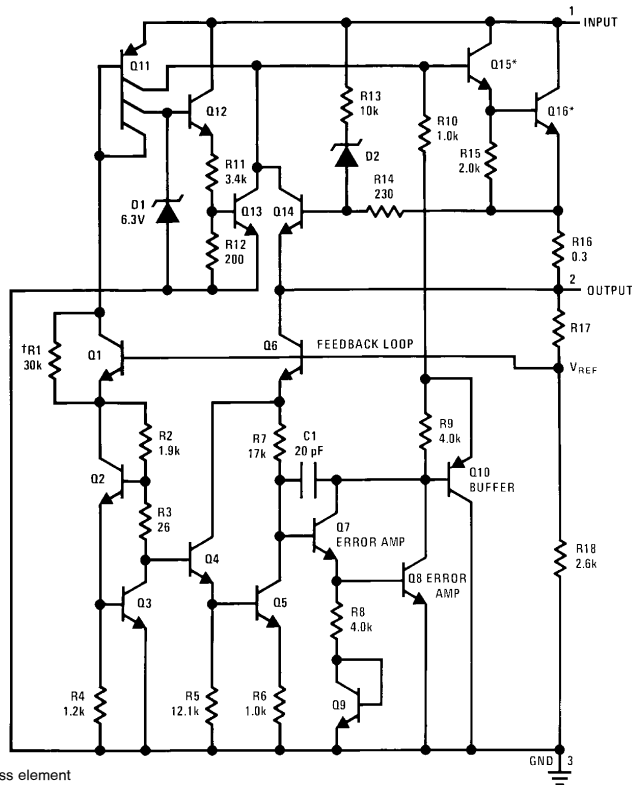

*Series pass element
†Starting up resistor

FIGURE 4. Complete Circuit of the LM340

TL/H/7413-4

Thermal Shut Down

In Figure 4 the V_{BE} of Q13 is clamped to 0.4V. When the die temperature reaches approximately $+175^{\circ}\text{C}$ the V_{BE} to turn on Q13 is 0.4V. When Q13 turns on it removes all base drive from Q15 which turns off the regulator thus preventing a further increase in die temperature.

Power Dissipation

The maximum power dissipation of the LM340 is given by:

$$P_{D\text{ MAX}} = (V_{IN\text{ MAX}} - V_{OUT}) I_{OUT\text{ MAX}} + V_{IN\text{ MAX}} I_Q \quad (1-6)$$

The maximum junction temperature (assuming that there is no thermal protection) is given by:

$$T_{JM} = \frac{36 - 13 I_{OUT\text{ MAX}} - (V_{IN} - V_{OUT})}{0.0855} + 25^{\circ}\text{C} \quad (1-7)$$

Example:

$V_{IN\text{ MAX}} = 23\text{V}$, $I_{OUT\text{ MAX}} = 1.0\text{A}$, LM340T-15.

Equation (1-7) yields: $T_{JM} = 200^{\circ}\text{C}$. So the T_j max of 150°C specified in the data sheet should be the limiting temperature.

From (1-6) $P_D \approx 8.1\text{W}$. The thermal resistance of the heat sink can be estimated from:

$$\theta_{s-a} = \frac{T_{JM\text{ MAX}} - T_A}{P_D} - (\theta_{j-c} + \theta_{c-s}) \quad (1-8)$$

The thermal resistance θ_{j-c} (junction to case) of the TO-220 package is 6°C/W , and assuming a θ_{c-s} (case to heat sink) of 0.4, equation (1-8) yields:

$$\theta_{s-a} = 8.4^{\circ}\text{C/W}$$

2. CURRENT SOURCE

The circuit shown on Figure 5 provides a constant output current (equal to $V_{OUT}/R1$ or 200 mA) for a variable

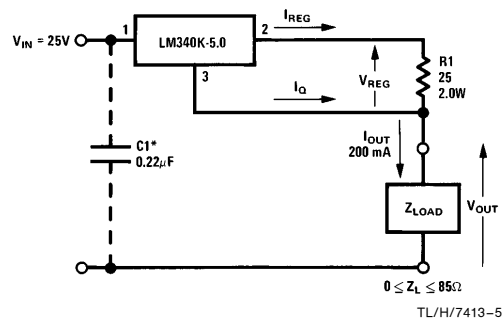

*Required if regulator is located far from power supply filter

FIGURE 5. Current Source

load impedance of 0 to 85Ω . Using the following definitions and the notation shown on Figure 5, Z_{OUT} and I_{OUT} are:

Q_{CC}/V = Quiescent current change per volt of input/output (pin 1 to pin 2) voltage change of the LM340

L_r/V = Line regulation per volt: the change in the LM340 output voltage per volt of input/output voltage change at a given I_{OUT} .

$$\Delta I_{OUT} = (Q_{CC}/V) \Delta V_{OUT} + \frac{L_r/V}{R1} \Delta V_{OUT} \quad (2-1)$$

$$Z_{OUT} = \frac{\Delta V_{OUT}}{\Delta I_{OUT}} \quad (2-2)$$

$$Z_{OUT} = \frac{\Delta V_{OUT}}{(Q_{CC}/V) \Delta V_{OUT} + \frac{(L_r/V)}{R1} \Delta V_{OUT}} \quad (2-3)$$

$$Z_{OUT} = \frac{1}{(Q_{CC}/V) + \frac{(L_r/V)}{R1}} \quad (2-4)$$

The LM340-5.0 data sheet lists maximum quiescent current change of 1.0 mA for a 7.0V to 25V change in input voltage; and a line regulation (interpolated for $I_{OUT} = 200\text{ mA}$) of 35 mV maximum for a 7.0V to 25V change in input voltage:

$$Q_{CC}/V = \frac{1.0\text{ mA}}{15\text{V}} = 55\text{ }\mu\text{A/V} \quad (2-5)$$

$$L_r/V = \frac{35\text{ mV}}{18\text{V}} \approx 2\text{ mV/V} \quad (2-6)$$

The worst case change in the 200 mA output current for a 1.0V change in output or input voltage using equation 2-1 is:

$$\frac{\Delta I_{OUT}}{1.0\text{V}} = 55\text{ }\mu\text{A} + \frac{2\text{ mV}}{25\Omega} = 135\text{ }\mu\text{A} \quad (2-7)$$

and the output impedance for a 0 to 85Ω change in Z_L using equation 2-4 is:

$$Z_{OUT} = \frac{1}{55\text{ }\mu\text{A} + \frac{2\text{ mV}}{25\Omega}} = 7.4\text{ k}\Omega \quad (2-8)$$

Typical measured values of Z_{OUT} varied from 10–12.3 k Ω , or 81–100 $\mu\text{A/V}$ change input or output (approximately 0.05%/V).

3. HIGH CURRENT REGULATOR WITH SHORT CIRCUIT CURRENT LIMIT

The 15V regulator circuit of Figure 6 includes an external boost transistor to increase output current capability to 5.0A. Unlike the normal boosting methods, it maintains the LM340's ability to provide short circuit current limiting and thermal shut-down without use of additional active components. The extension of these safety features to the external pass transistor Q1 is based on a current sharing scheme

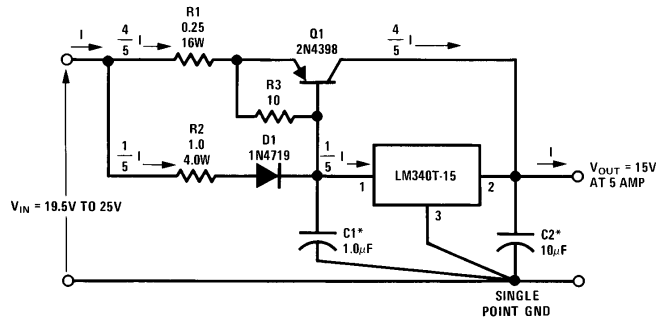

*Solid tantalum

Note 1: Current sharing between the LM340 and Q1 allows the extension of short circuit current limit, safe operating area protection, and (assuming Q1's heat sink has four or more times the capacity of the LM340 heat sink) thermal shutdown protection.

Note 2: I_{SHORT CIRCUIT} is approximately 5.5 amp.

Note 3: I_{OUT MAX} at V_{OUT} = 15V is approximately 9.5 amp.

FIGURE 6. 15V 5.0A Regulator with Short Circuit Current Limit

using R1, R2, and D1. Assuming the base-to-emitter voltage of Q1 and the voltage drop across D1 are equal, the voltage drops across R1 and R2 are equal. The currents through R1 and R2 will then be inversely proportional to their resistances. For the example shown on *Figure 6*, resistor R1 will have four times the current flow of R2. For reasonable values of Q1 beta, the current through R1 is approximately equal to the collector current of Q1; and the current through R2 is equal to the current flowing through the LM340. Therefore, under overload or short circuit conditions the protection circuitry of the LM340 will limit its own output current and, because of the R1/R2 current sharing scheme, the output current of Q1 as well. Thermal overload protection also extends Q1 when its heat sink has four or more times the capacity of the LM340 heat sink. This follows from the fact that both devices have approximately the same input/output voltage and share the load current in a ratio of four to one.

The circuit shown on *Figure 6* normally operates at up to 5.0A of output current. This means up to 1.0A of current flows through the LM340 and up to 4.0A flows through Q1. For short term overload conditions the curve of *Figure 7* shows the maximum instantaneous output current versus temperature for the boosted regulator. This curve reflects the approximately 2.0A current limit of the LM340 causing an 8.0A current limit in the pass transistor, or 10A, total.

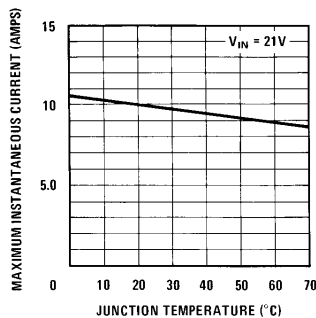

FIGURE 7. Maximum Instantaneous Current vs Junction Temperature

Under continuous short circuit conditions the LM340 will heat up and limit to a steady total state short circuit current of 4.0A to 6.0A as shown in *Figure 8*. This curve was taken using a Wakefield 680-75 heat sink (approximately 7.5°C/W) at a 25°C ambient temperature.

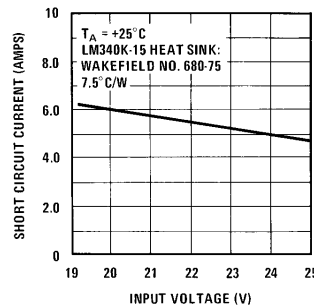

FIGURE 8. Continuous Short Circuit Current vs Input Voltage

For optimum current sharing over temperature between the LM340 and Q1, the diode D1 should be physically located close to the pass transistor on the heat sink in such a manner as to keep it at the same temperature as that of Q1. If the LM340 and Q1 are mounted on the same heat sink the LM340 should be electrically isolated from the heat sink since its case (pin 3) is at ground potential and the case of Q1 (its collector) is at the output potential of the regulator. Capacitors C1 and C2 are required to prevent oscillations and improve the output impedance respectively. Resistor R3 provides a path to unload excessive base charge from the base of Q1 when the regulator goes suddenly from full load to no load. The single point ground system shown on *Figure 6* allows the sense pins (2 and 3) of the LM340 to monitor the voltage directly at the load rather than at some point along a (possibly) resistive ground return line carrying up to 5.0A of load current. *Figure 9* shows the typical variation of load regulation versus load current for the boosted regulator. The insertion of the external pass transistor increases the input/output differential voltage from 2.0V to

approximately 4.5V. For an output current less than 5.0A, the R2/R1 ratio can be set lower than 4:1. Therefore, a less expensive PNP transistor may be used.

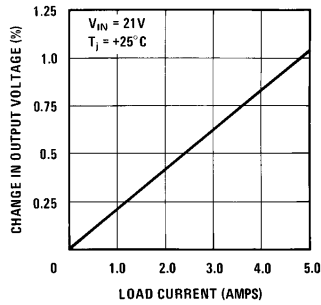

FIGURE 9. Load Regulation

TL/H/7413-9

4. 5.0V, 5.0A VOLTAGE REGULATOR FOR TTL

The high current 5.0V regulator for TTL shown in Figure 10 uses a relatively inexpensive NPN pass transistor with a lower power PNP device to replace the single, higher cost, power PNP shown in Figure 6. This circuit provides a 5.0V output at up to 5.0A of load current with a typical load regulation of 1.8% from no load to full load. The peak instantaneous output current observed was 10.4A at a 25°C junction temperature (pulsed load with a 1.0 ms ON and a 200 ms OFF period) and 8.4A for a continuous short circuit. The typical line regulation is 0.02% of input voltage change ($I_{OUT} = 0$).

One can easily add an overload indicator using the National's new NSL5027 LED. This is shown with dotted lines in Figure 10. With this configuration R2 is not only a current sharing resistor but also an overload sensor. R5 will determine the current through the LED; the diode D2 has been added to match the drop across D1. Once the load current exceeds 5.0A (1.0A through the LM340 assuming perfect current sharing and $V_{D1} = V_{D2}$) Q3 turns ON and the overload indicator lights up.

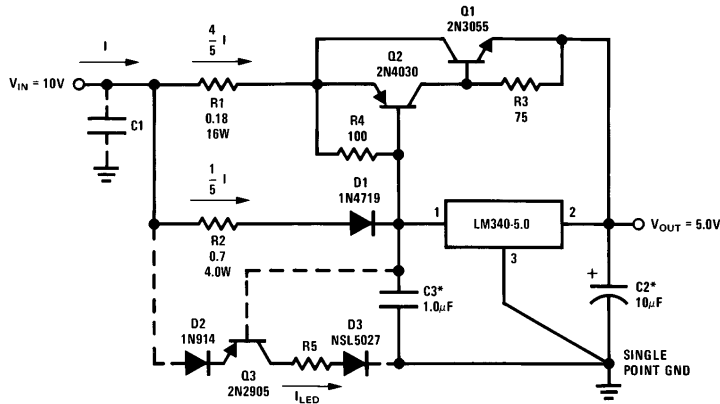

*Solid tantalum

FIGURE 10. 5.0V, 5.0A Regulator for TTL (with short circuit, thermal shutdown protection, and overload indicator)

TL/H/7413-10

Example:

$$I_{OVERLOAD} = 5.0A$$

$$I_{LED} = 40 \text{ mA (light intensity of 16 mcd)}$$

$$V_{LED} = 1.75, R5 \approx \frac{V_{IN} - 2.65}{I_{LED}} \quad (4-1)$$

5. ADJUSTABLE OUTPUT VOLTAGE REGULATOR FOR INTERMEDIATE OUTPUT VOLTAGES

The addition of two resistors to an LM340 circuit allows a non-standard output voltage while maintaining the limiting features built into IC. The example shown in Figure 11 provides a 10V output using an LM340K-5.0 by raising the reference (pin number 3) of the regulator by 5.0V.

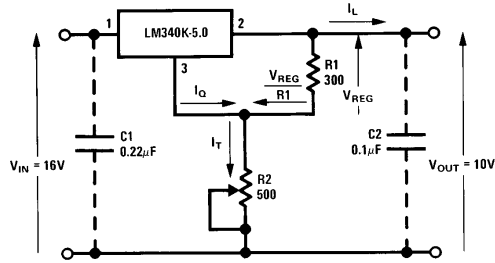

FIGURE 11. 10V Regulator

TL/H/7413-11

The 5.0V pedestal results from the sum of regulator quiescent current I_Q and a current equal to $V_{REG}/R1$, flowing through potentiometer R2 to ground. R2 is made adjustable to compensate for differences in I_Q and V_{REG} output. The circuit is practical because the change in I_Q due to line voltage and load current changes is quite small.

The line regulation for the boosted regulator is the sum of the LM340 line regulation, its effects on the current through

voltage of the regulator is therefore raised to a level set by the value of the resistive divider R1, R2, R3 and limited by the input voltage. With the resistor values shown in Figure 12, the output voltage is variable from 7.0V to 23V and the maximum output current (pulsed load) varies from 1.2A to 2.0A ($T_j = 25^\circ\text{C}$) as shown in Figure 13.

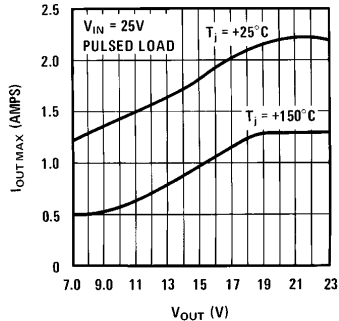

TL/H/7413-13

FIGURE 13. Maximum Output Current

Since the LM101A is operated with a single supply (the negative supply pin is grounded). The common mode voltage V_B must be at least at a $2.0 V_{BE} + V_{SAT}$ above ground. R3 has been added to insure this when $R2 = 0$. Furthermore the bias current I_B of the operational amplifier should be negligible compared to the current flowing through the resistive divider.

Example:

$$V_{IN} = 25V$$

$$V_{OUT\ MIN} = 5 + V_B, (R2 = 0),$$

$$V_B = R3 (I - I_B) = 2.0V$$

$$R1 = 2.5 R3$$

$$V_{OUT\ MAX} = V_{IN} - \text{dropout volt.}$$

$$(R2 = R2_{MAX})$$

$$R2_{MAX} = 3.3 R1$$

So setting R3, the values of R1 and R2 can be determined.

If the LM324 is used instead of the LM101A, R3 can be omitted since its common mode voltage includes the ground, and then the output will be adjustable from 5 to a certain upper value defined by the parameters of the system.

The circuit exhibits the short-circuit protection and thermal shutdown properties of the LM340 over the full output range.

The load regulation can be predicted as:

$$\Delta V_{OUT} = \frac{R1 + R2 + R3}{R1} \Delta V_{340} \quad (6-1)$$

where ΔV_{340} is the load regulation of the device given in the data sheet. To insure that the regulator will start up under full load a reverse biased small signal germanium diode, 1N91, can be added between pins 2 and 3.

7. VARIABLE OUTPUT REGULATOR 0.5V-29V

When a negative supply is available an approach equivalent to that outlined in section 6 may be used to lower the minimum output voltage of the regulator below the nominal voltage that of the LM340 regulator device. In Figure 14 the voltage V_G at the ground pin of the regulator is determined by the drop across R1 and the gain of the amplifier. The current I may be determined by the following relation:

$$I = \frac{V_{340}}{R1} \frac{R2 R5 - R3 R4}{R4 (R2 + R3)} + \frac{V_{IN^-}}{R1} \quad (7-1)$$

or if $R2 + R3 = R4 + R5 = R$

$$I = \frac{V_{340} R2}{R1 R4} + \frac{1}{R1} (V_{IN^-} - V_{340}) \quad (7-2)$$

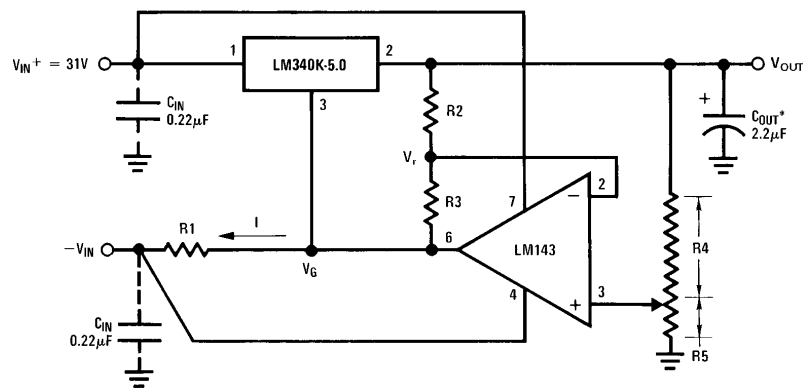

TL/H/7413-14

FIGURE 14. Variable Output Voltage 0.5V-30V

considering that the output is given by:

$$V_{OUT} = V_G + V_{340} \quad (7-3)$$

and

$$V_G = R_1 I - V_{IN}^- \quad (7-4)$$

combining 7-2, 7-3, 7-4 an expression for the output voltage is:

$$V_{OUT} = V_{340} \frac{R_2}{R_4} \quad (7-5)$$

Notice that the output voltage is inversely proportional to R4 so the output voltage may be adjusted very accurately for low values. A minimum output of 0.5V has been set. This implies that

$$\frac{R_2}{R_4} = 0.1 \frac{R_3}{R_4} = 0.9 \frac{R_3}{R_2} = 9 \quad (7-6)$$

An absolute zero output voltage will require $R_4 = \infty$ or $R_2 = 0$, neither being practical in this circuit. The maximum output voltage as shown in Figure 14 is 30V if the high voltage operational amplifier LM143 is used. If only low values of V_{OUT} are sought, then an LM101 may be used. R1 can be computed from:

$$R_1 = \frac{V_{IN}^-}{I_{Q340}} \quad (7-7)$$

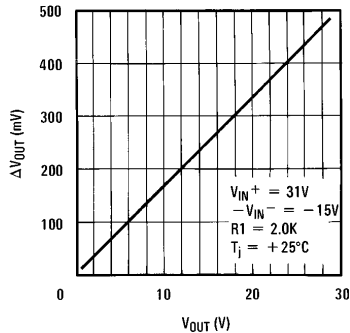

TL/H/7413-15

FIGURE 15. Typical Load Regulation for a 0.5V – 30V Regulator ($\Delta I_{OUT} = 1.0A$)

Figure 15 illustrates the load regulation as a function of the output voltage.

8. DUAL POWER SUPPLY

The plus and minus regulators shown in Figure 16 will exhibit line and load regulations consistent with their specifications as individual regulators. In fact, operation will be entirely normal until the problem of common loads occurs. A 30Ω load from the +15V output to the -15V output (representing a 0.5A starting load for the LM340K-15 if the LM320K-15 is already started) would allow start up of the LM340 in most cases. To insure LM340 startup over the full temperature range into a worst case 1.0A current sink load the germanium power "diode" D1 has been added to the circuit. Since the forward voltage drop of the germanium diode D1 is less than that of the silicon substrate diode of the LM340 the external diode will take any fault current and allow the LM340 to start up even into a negative voltage load. D1 and silicon diode D2 also protect the regulator outputs from inadvertent shorts between outputs and to ground. For shorts between outputs the voltage difference between either input and the opposite regulator output should not exceed the maximum rating of the device.

The example shown in Figure 16 is a symmetrical $\pm 15V$ supply for linear circuits. The same principle applies to non-symmetrical supplies such as a +5.0V and -12V regulator for applications such as registers.

9. TRACKING DUAL REGULATORS

In Figure 17, a fraction of the negative output voltage "lifts" the ground pins of the negative LM320K-15 voltage regulator and the LM340K-15 through a voltage follower and an inverter respectively. The dual operational amplifier LM1558 is used for this application and since its supply voltage may go as high as $\pm 22V$ the regulator outputs may be set between 5.0V and 20V. Because of the tighter output tolerance and the better drift of the LM320, the positive regulator is made to track the negative. The best tracking action is achieved by matching the gain of both operational amplifiers, that is, the resistors R2 and R3 must be matched as closely as possible.

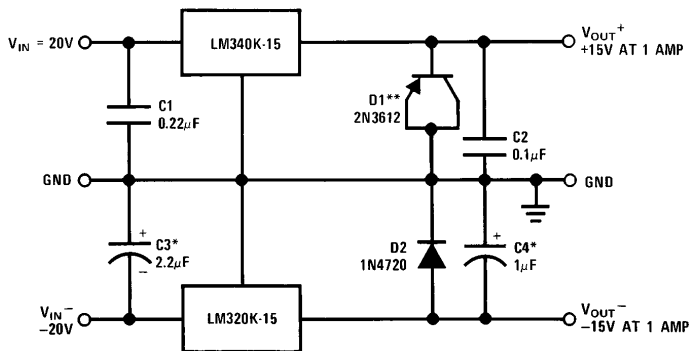

TL/H/7413-16

*Solid tantalum

**Germanium diode (using a PNP germanium transistor with the collector shorted to the emitter)

Note: C1 and C2 required if regulators are located far from power supply filter.

FIGURE 16. Dual Power Supply

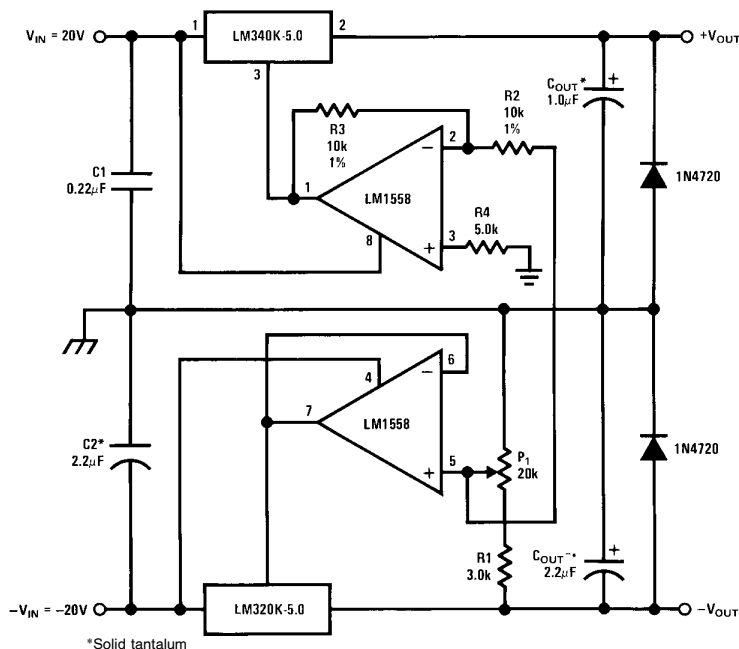

FIGURE 17. Tracking Dual Supply $\pm 5.0V - \pm 18V$

TL/H/7413-17

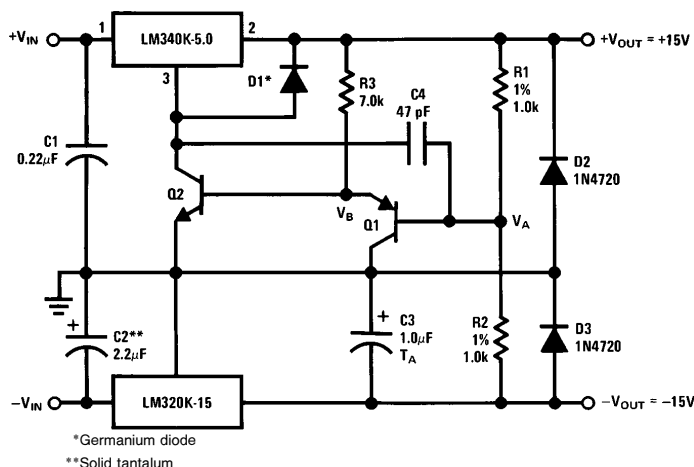

FIGURE 18. Tracking Dual Supply $\pm 15V$

TL/H/7413-18

Indeed, with R2 and R3 matched to better than 1%, the LM340 tracks the LM320 within 40–50 mV over the entire output range. The typical load regulation at $V_{OUT} = \pm 15V$ for the positive regulator is 40 mV from a 0 to 1.0A pulsed load and 80 mV for the negative.

Figure 18 illustrates $\pm 15V$ tracking regulator, where again the positive regulator tracks the negative. Under steady state conditions V_A is at a virtual ground and V_B at a V_{BE} above ground. Q2 then conducts the quiescent current of the LM340. If $-V_{OUT}$ becomes more negative the collector base junction of Q1 is forward biased thus lowering V_B and raising the collector voltage of Q2. As a result $+V_{OUT}$ rises and the voltage V_A again reaches ground potential.

Assuming Q1 and Q2 to be perfectly matched, the tracking action remains unchanged over the full operating temperature range.

With R1 and R2 matched to 1%, the positive regulator tracks the negative within 100 mV (less than 1%). The capacitor C4 has been added to improve stability. Typical load regulations for the positive and negative sides from a 0 to 1.0A pulsed load ($t_{ON} = 1.0$ ms, $t_{OFF} = 200$ ms) are 10 mV and 45 mV respectively.

10. HIGH INPUT VOLTAGE

The input voltage of the LM340 must be kept within the limits specified in the data sheet. If the device is operated

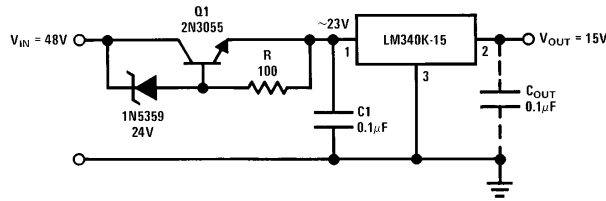

*Heat sink Q1 and LM340

FIGURE 19. High Input Voltage

TL/H/7413-19

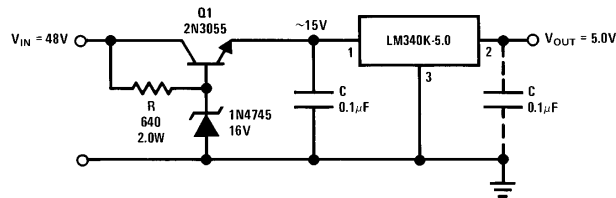

*Heat sink Q1 and LM340

FIGURE 20. High Input Voltage

TL/H/7413-20

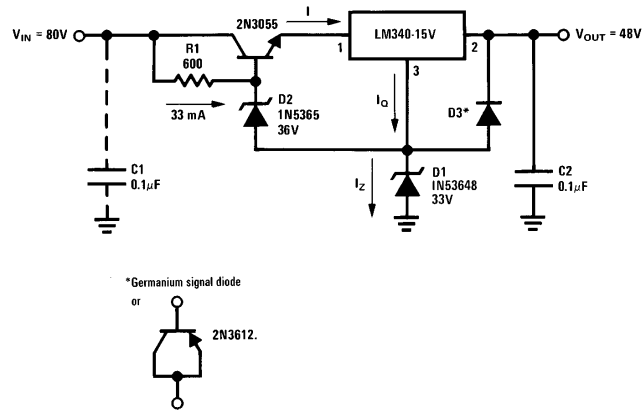

*Germanium signal diode

or

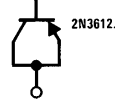

FIGURE 21. High Voltage Regulator

TL/H/7413-21

above the absolute maximum input voltage rating, two failure modes may occur. With the output shorted to ground, the series pass transistor Q16 (see Figure 4) will go to avalanche breakdown; or, even with the output not grounded, the transistor Q1 may fail since it is operated with a collector-emitter voltage approximately 4.0V below the input.

If the only available supply runs at a voltage higher than the maximum specified, one of the simplest ways to protect the regulator is to connect a zener diode in series with the input of the device to level shift the input voltage. The drawback to this approach is obvious. The zener must dissipate $(V_{SUPPLY} - V_{IN\ MAX\ LM340}) \cdot (I_{OUT\ MAX})$ which may be several watts. Another way to overcome the over voltage problem is illustrated in Figure 19 where an inexpensive, NPN-zener-resistor, combination may be considered as an equivalent to the power zener. The typical load regulation of this circuit is 40 mV from 0 to 1.0A pulsed load ($T_j = 25^\circ\text{C}$) and the line regulation is 2.0 mV for 1.0V variation in the input voltage ($I_{OUT} = 0$). A similar alternate approach is shown in Figure 20.

With an optional output capacitor the measured noise of the circuit was $700\ \mu\text{Vp-p}$.

11. HIGH VOLTAGE REGULATOR

In previous sections the principle of "lifting the ground terminal" of the LM340, using a resistor divider or an operational amplifier, has been illustrated. One can also raise the output voltage by using a zener diode connected to the ground pin as illustrated in the Figure 21 to obtain an output level increased by the breakdown voltage of the zener. Since the input voltage of the regulator has been allowed to go as high as 80V a level shifting transistor-zener (D2)—resistor combination has been added to keep the voltage across the LM340 under permissible values. The disadvantage of the system is the increased output noise and output voltage drift due to the added diodes.

Indeed it can be seen that, from no load to full load conditions, the ΔI_Z will be approximately the current through R1 ($\approx 35\ \text{mA}$) and therefore the degraded regulation caused by D1 will be V_Z (at $35\ \text{mA} + I_Q$) - V_Z (at I_Q).

The measured load regulation was 60 mV for ΔI_{OUT} of 5.0 mA to 1.0A (pulsed load), and the line regulation is 0.01%V of input voltage change ($I_{OUT} = 500$ mA) and the typical output noise 2.0 mVp-p ($C_2 = 0.1 \mu\text{F}$). The value of R1 is calculated as:

$$R1 \cong \beta \left[\frac{V_{IN} - (V_{Z1} + V_{Z2})}{I_{\text{full load}}} \right] \quad (11-1)$$

12. ELECTRONIC SHUTDOWN

Figure 22 shows a practical method of shutting down the LM340 under the control of a TTL or DTL logic gate. The pass transistor Q1 operates either as a saturated transistor or as an open switch. With the logic input high (2.4V specified minimum for TTL logic) transistor Q2 turns on and pulls 50 mA down through R2. This provides sufficient base drive

to maintain Q1 in saturation during the ON condition of the switch. When the logic input is low (0.4V specified maximum for TTL logic) Q2 is held off, as is Q1; and the switch is in the OFF condition. The observed turn-on time was 7.0 μs for resistive loads from 15 Ω to infinity and the turn-off time varied from approximately 3.0 μs for a 15 Ω load to 3.0 ms for a no-load condition. Turn-off time is controlled primarily by the time constant of R_{LOAD} and C1.

13. VARIABLE HIGH VOLTAGE REGULATOR WITH OVERVOLTAGE SHUTDOWN

A high voltage variable-output regulator may be constructed using the LM340 after the idea illustrated in section 7 and drawn in Figure 23. The principal inconvenience is that the voltage across the regulator must be limited to maximum

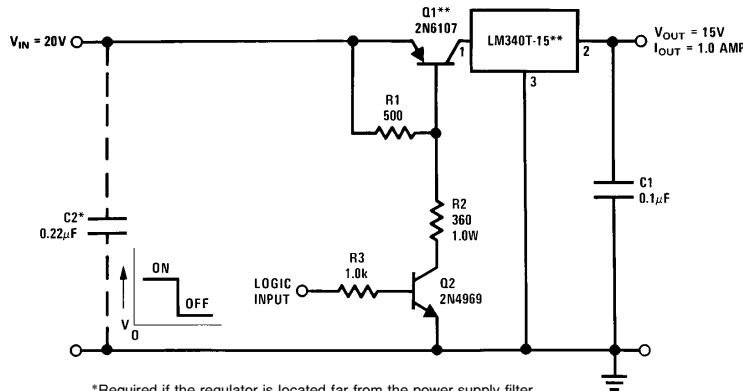

*Required if the regulator is located far from the power supply filter

**Head sink Q1 and the LM340

TL/H/7413-22

FIGURE 22. Electronic Shutdown Circuit

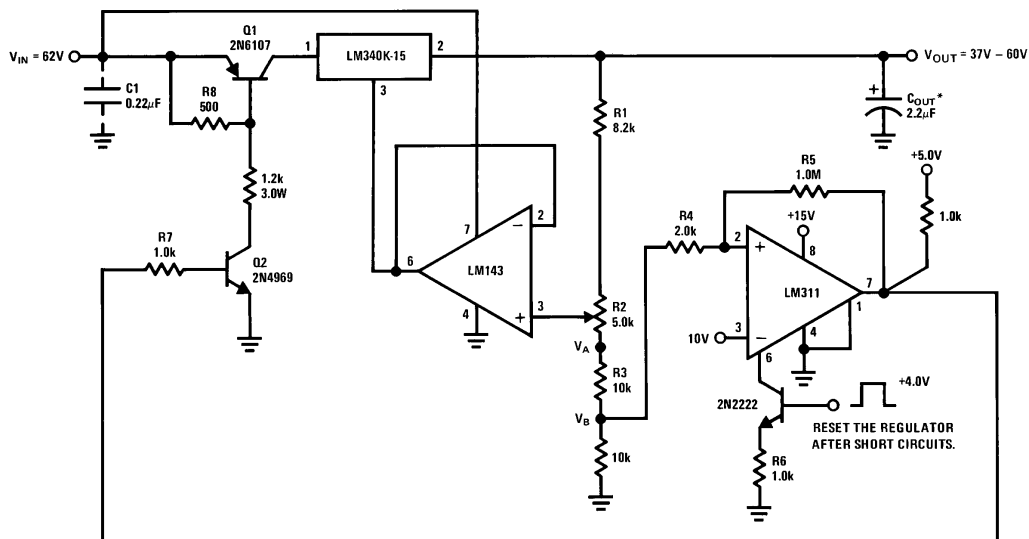

*Solid tantalum

TL/H/7413-23

FIGURE 23. Variable High Voltage Regulator with Shortcircuit and Overvoltage Protection

rating of the device, the higher the applied input voltage the higher must be lifted the ground pin of the LM340. Therefore the range of the variable output is limited by the supply voltage limit of the operational amplifier and the maximum voltage allowed across the regulator. An estimation of this range is given by:

$$V_{OUT\ MAX} - V_{OUT\ MIN} = V_{SUPPLY\ MAX340} - V_{NOMINAL340} - 2.0V \quad (13-1)$$

Examples:

$$LM340-15: V_{OUTMAX} - V_{OUTMIN} = 35 - 15 - 2 = 18V$$

Figure 23 illustrates the above considerations. Even though the LM340 is by itself short circuit protected, when the output drops, also V_A drops and the voltage difference across the device increases. If it exceeds 35V the pass transistor internal to the regulator will breakdown, as explained in section 11. To remedy this, an over-voltage shutdown is includ-

ed in the circuit. When the output drops the comparator switches low, pulls down the base Q2 thus opening the switch Q1, and shutting down the LM340. Once the short circuit has been removed the LM311 must be activated through the strobe to switch high and close Q1, which will start the regulator again. The additional voltages required to operate the comparator may be taken from the 62V since the LM311 has a certain ripple rejection and the reference voltage (pin 3) may have a superimposed small ac signal. The typical load regulation can be computed from equation 6-1.

BIBLIOGRAPHY

1. AN-42: "IC Provides on Card Regulation for Logic Circuits."
2. Carl T. Nelson: "Power distribution and regulation can be simple, cheap and rugged." EDN, February 20, 1973.

LIFE SUPPORT POLICY

NATIONAL'S PRODUCTS ARE NOT AUTHORIZED FOR USE AS CRITICAL COMPONENTS IN LIFE SUPPORT DEVICES OR SYSTEMS WITHOUT THE EXPRESS WRITTEN APPROVAL OF THE PRESIDENT OF NATIONAL SEMICONDUCTOR CORPORATION. As used herein:

1. Life support devices or systems are devices or systems which, (a) are intended for surgical implant into the body, or (b) support or sustain life, and whose failure to perform, when properly used in accordance with instructions for use provided in the labeling, can be reasonably expected to result in a significant injury to the user.
2. A critical component is any component of a life support device or system whose failure to perform can be reasonably expected to cause the failure of the life support device or system, or to affect its safety or effectiveness.



National Semiconductor Corporation
1111 West Bardin Road
Arlington, TX 76017
Tel: 1(800) 272-9959
Fax: 1(800) 737-7018

National Semiconductor Europe
Fax: (+49) 0-180-530 85 86
Email: cnjwge@tevm2.nsc.com
Deutsch Tel: (+49) 0-180-530 85 85
English Tel: (+49) 0-180-532 78 32
Français Tel: (+49) 0-180-532 93 58
Italiano Tel: (+49) 0-180-534 16 80

National Semiconductor Hong Kong Ltd.
19th Floor, Straight Block,
Ocean Centre, 5 Canton Rd.
Tsimshatsui, Kowloon
Hong Kong
Tel: (852) 2737-1600
Fax: (852) 2736-9960

National Semiconductor Japan Ltd.
Tel: 81-043-299-2309
Fax: 81-043-299-2408